

Materials Decathlon - Challenge n°10 - 40'

ECO-ALTERNATIVE TO DISPOSABLE PLASTIC PLATES

Everyday in a big city like Milan thousands of students eat in school canteens. By the end of the year the number of plastic disposable sets (dish, knife and fork, glass, etc.) thrown away amounts to approx. 13 millions. 550 tons of plastic sent to the incinerator (since due to food contamination this plastic cannot be recycled!). Multiply it for all Italian schools and ... you will swim in a sea of plastic! Quite recently a new biocompatible kind of plate has come into the market and has already been adopted by many municipalities for their school canteens. It looks like a plate made of biscuit. It can contain liquid and semiliquid for approx. one hour before melting. The manufacturer also states that it **keeps food warmer for a longer time**. Let's test this comparing three different kinds of plates: a) disposable plastic; b) classic ceramic; c) biocompatible biscuit.

On the desk you have the three plates and some hot "food" [Actually it's only hot water!! Let's imagine it's some kind of soup!!]. Once the "food" is poured into the plates we will monitor temperature and plot the three cooling curves. We will use Arduino with three temperature sensors. This will NOT plot a real time graph but data collection will be shown on the serial monitor, then data may be pasted and copied in Excel to make ONE graph with THREE cooling curves.

Warning: be careful to put the same quantity of "food" into each plate; the initial temperature of the food should be the same as you have taken it from the same "pot".

1. **The circuit** - Each sensor needs a 10kOhm resistor. Connections are

- One leg of the temp probe to the Ground (GND) (black)
- The second leg of the probe connected to the 10kOhm resistor
- The second leg of the resistor to VCC 3,3 V (red)
- The common ends (green, yellow, blue) are the signal and go to A0, A1, A2 respectively
- AREF to VCC3,3 V (red cable on top)

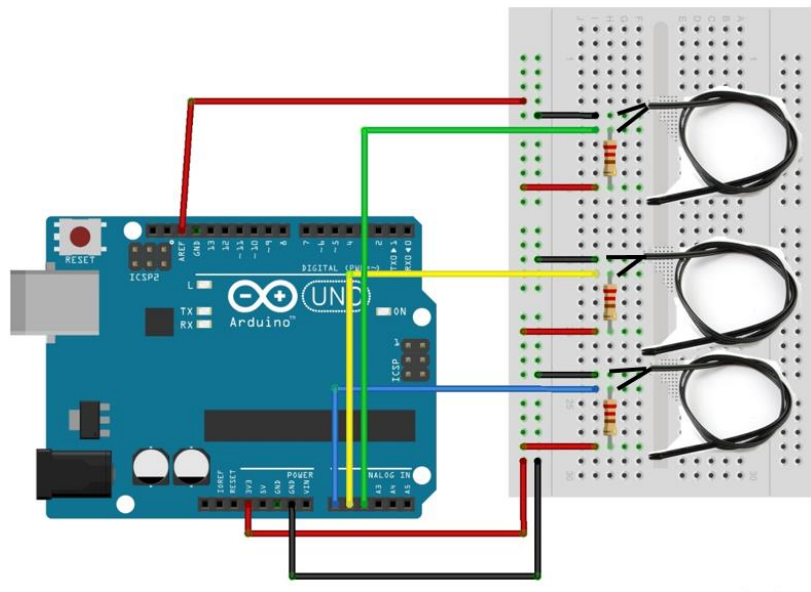

2. **The Code** ¹ Use

"**3_thermistor_aref_2.ino**". You can modify the acquisition rate (now it is set to 10 seconds)

3. **Data collection** - Insert the temperature probes in the three plates and start data collection. Open the serial monitor to see the readings scrolling with time. Take measure for at least 15'.

4. Copy the data and paste them in a TXT file, then import in Excel and plot the comparative graph.

OUTPUT WANTED: plot of the three cooling curves + short comment on the features of the different plates. **Paste everything on a word file and save it on the PC at your disposal.**

¹ See Teachers' Guide



Pappami!

Il piatto che si mangia!



Co-funded by the
Erasmus+ Programme
of the European Union

This project has received funding from the European Union's Erasmus + Programme for Education under KA2 grant 2014-1-IT02-KA201-003604. The European Commission support for the production of these didactical materials does not constitute an endorsement of the contents which reflects the views only of the authors, and the Commission cannot be held responsible for any use which may be made of the information contained therein.



All MoM-Matters of Matter materials, this sheet included, belong to MoM Authors (www.mattersofmatter.eu) and are distributed under Creative Commons 4.0 not commercial share alike license as OER Open Educational Resources